

FITTING INSTRUCTION

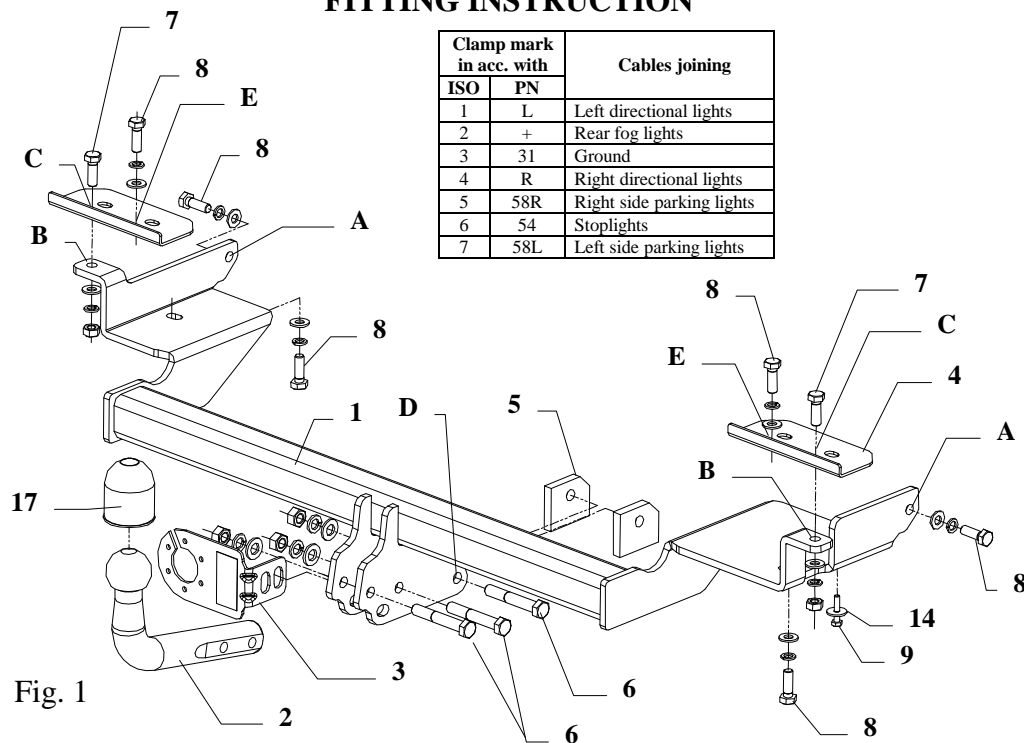

Clamp mark in acc. with		Cables joining
ISO	PN	
1	L	Left directional lights
2	+	Rear fog lights
3	31	Ground
4	R	Right directional lights
5	58R	Right side parking lights
6	54	Stoptights
7	58L	Left side parking lights

Fig. 1

This towbar is designed to assembly in following cars: **VOLVO S40, 4 doors** and **VOLVO V40 ESTATE**, both produced since 1996 till 06.2000, catalogue no. **L13** and is prepared to tow trailers max total weight **1600 kg** and max vertical load **75 kg**.

From manufacturer

Thank you for buying our product. Their reliability has been confirmed in many tests. Reliability of towbar depends also on correct assembly and right operation. For this reasons we kindly ask to read carefully this instruction and apply to hints.

The towbar should be install in points described by a car producer.

The instruction of the assembly

1. Remove boot upholstery and panels from bottom.
2. Disassemble a bumper.
3. Unscrew last muffler handle and thermal shield.
4. Put towbar to chassis – holes pos. A agree to holes in chassis members and screw it using four bolts M10x1.25x30mm (pos. 8) and plain and spring washers.
5. Through holes pos. B drill boot floor using bit $\phi 10,5$ mm. Put fish-plates pos. 4 on holes pos. C and on drilled hole and screw all using bolts M10x30mm (pos. 7) and plain washer (loosely).
6. Through holes pos. D and distance washers (pos. 5) screw with original tow handle.
7. Assemble bumper (cut out fragment – see fig. 2).
8. Assemble bumper using two bolts M10x1.25x30mm (pos. 8), through threaded holes inside bumper, this bolts put through holes pos. E in element pos. 4.
9. Assemble thermal shield through towbar hole using bolt M6x30mm (pos. 9).
10. Assemble rest of parts in reverse order.
11. Fix tow-ball (pos. 2) and socket plate (pos. 3) using bolts M12x75mm (pos. 6) from accessories.
12. Tighten all bolts according to the torque shown in the table.
13. Connect electric wires of 7-poles socket according to the instruction of the car. (Recommend to make at authorized service station).
14. Supplement the paint coating damaged during assembly.

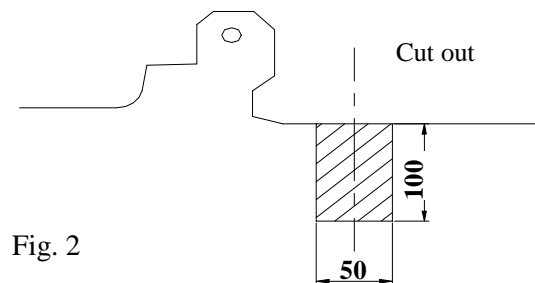

Fig. 2

Torque settings for nuts and bolts (8,8):	
M 8 - 25 Nm	M 10 - 55 Nm
M 12 - 85 Nm	M 14 - 135 Nm











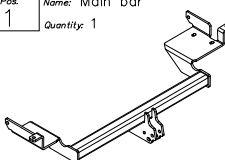



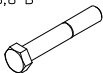

NOTE

After install the towbar you should get adequate registration in registration book (at authorised service station).The car should be equipped with:

- Indicators
- Tow mirrors

After 1000km check all bolts and nuts. The ball of towbar must be always kept clear and conserve with a grease.

Towbar accessories:

Pos. 1 Name: Main bar Quantity: 1 	Pos. 5 Name: Distance fish-plate Quantity: 2 	Pos. 10 Name: Nut 8 B Quantity: 3 Dim.: M12 	Pos. 15 Name: Spring washer Quantity: 3 Dim.: Ø 12,2 mm 
	Pos. 6 Name: Bolt 8,8 B Quantity: 3 Dim.: M12x75mm 	Pos. 11 Name: Nut 8 B Quantity: 2 Dim.: M10 	Pos. 16 Name: Spring washer Quantity: 8 Dim.: Ø 10,2 mm 
Pos. 2 Name: Tow ball Quantity: 1 	Pos. 7 Name: Bolt 8,8 B Quantity: 2 Dim.: M10x30mm 	Pos. 12 Name: Plain washer Quantity: 3 Dim.: Ø 13 mm 	Pos. 17 Name: Ball cover Quantity: 1 
Pos. 3 Name: Socket plate Quantity: 1 	Pos. 8 Name: Bolt 8,8 B Quantity: 6 Dim.: M10x1,25x30mm 	Pos. 13 Name: Plain washer Quantity: 8 Dim.: Ø 10,5 mm 	
Pos. 4 Name: Fish-plate Quantity: 2 	Pos. 9 Name: Bolt 8,8 B Quantity: 1 Dim.: M6x30mm 	Pos. 14 Name: Washer Quantity: 1 Dim.: Ø22xØ6,5x1,5mm 	



PPUH AUTO-HAK S.J.

Produkcja Haków Holowniczych
Henryk & Zbigniew Nejman
76-200 SŁUPSK ul. Słoneczna 16K
tel/fax (059) 8-414-414; 8-414-413
email: office@autohak.com.pl
www.autohak.com.pl

Towing hitch (without electrical set)

Class: **A50-X** Cat. no. **L 13**

Designed for:

Manufacturer: **VOLVO**

Model: **S40 4 doors**

V40 ESTATE

both produced since 1996 till 06.2000

Technical data:

D-value: 8,39 kN

maximum trailer weight: **1600 kg**

maximum vertical cup load: **75 kg**

Approval number acc. to regulations EKG/ONZ 55.01: **E20-55R-01 1172**

Foreword

This towbar is designed according to rules of safety traffic regulations. The towing hitch is a safety component and can be install only by qualified personnel. Any alteration or conversion of the towing hitch is prohibited and would lead to cancellation of design certification. Remove insulating compound and underseal from vehicle (if present) in the area of the matting surfaces of the towing hitch. The vehicle manufacturer's specifications regarding trailer load and max. vertical cup load are decisive for driving whereat values for the towing hitch cannot be exceeded.

D-value formula:

$$\frac{\text{Max trailer weight [kg]} \times \text{Max vehicle weight [kg]}}{\text{Max trailer weight [kg]} + \text{Max vehicle weight [kg]}} \times \frac{9,81}{1000} = D \text{ [kN]}$$